



CLARKE-GRAVELY CORPORATION
A Studebaker-Worthington Company

SET UP INSTRUCTIONS

NAME: GRAVELY SNOWBLOWERS

PART NUMBER(S): 28" - 20979
34" - 20980
38" - 20981
44" - 20982

1. Put the hose connector over the end of the shaft and fasten with the hose clamp as shown in figure 1.

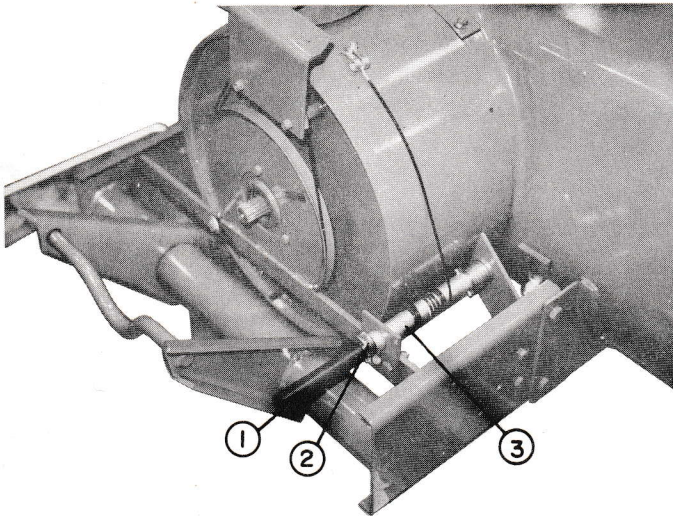

- 1 — Hose Connector
- 2 — Hose Clamp
- 3 — Shaft

Figure 1

2. Fasten the crank support to the snowblower support frame with the 3/8" x 2" bolts and 3/8" nuts as shown in figure 2.

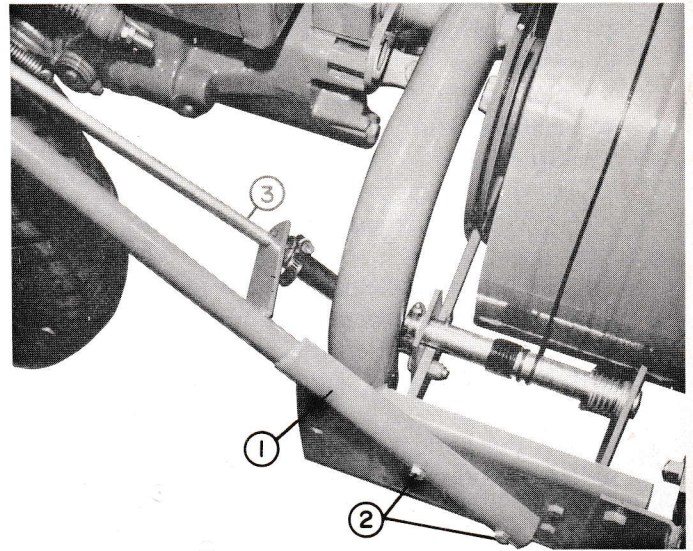

- 1 — Crank Support
- 2 — Bolts
- 3 — Crank

Figure 2

3. Put the spring pin into the hole of the crank handle. Put the handle grip on the crank and fasten with the stud cap. See figure 3.

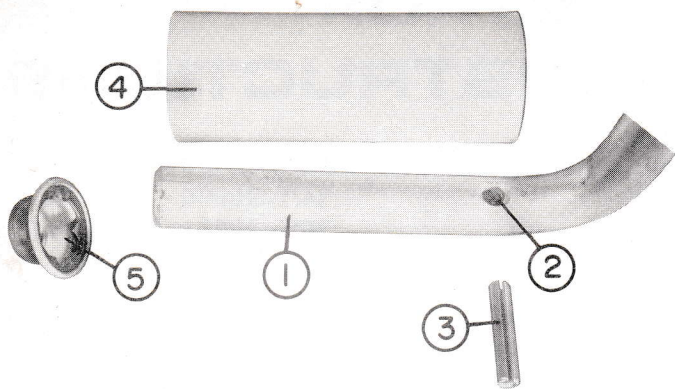

- 1 — Crank Handle
- 2 — Hole
- 3 — Spring Pin
- 4 — Handle Grip
- 5 — Stud Cap

Figure 3

6. Put a flat washer on the chute studs and then the chute deflector. Put another flat washer on the studs and fasten with the 1/4" lock nuts as shown in figure 4.
7. Put a flat washer and a lock washer on the adjusting stud. Fasten with the wing nut as shown in figure 4.

4. Put the other hose clamp on the hose connector. Put the crank through the holes in the crank support and into the hose connector and fasten with the hose clamp as shown in figure 2.
5. Fasten the deflector baffle to the chute with the baffle retainer, screws and nuts as shown in figure 4.

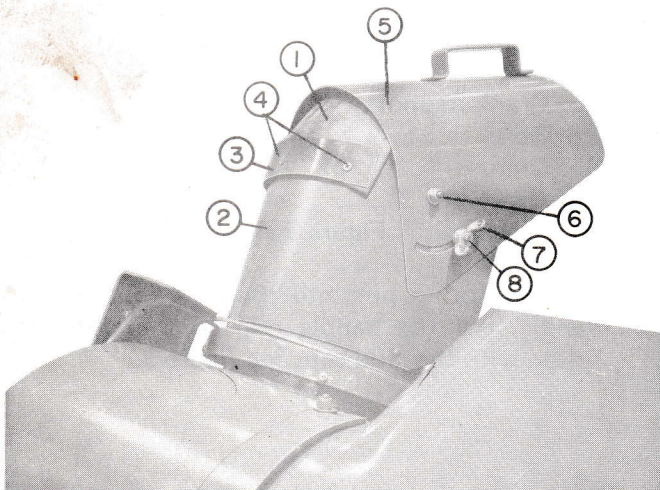

- 1 — Deflector Baffle
- 2 — Chute
- 3 — Baffle Retainer
- 4 — Screws
- 5 — Chute Deflector
- 6 — Stud
- 7 — Wing Nut
- 8 — Adjusting Stud

Figure 4